

USE AND MAINTENANCE INSTRUCTION MANUAL FOR THE OIL TRANSFER AND FILTRATION PACKAGE



MODEL

UOW040M0075A3XX

Legislative Decree January 27, 2010 no. 17

(Assimilation of the 2006/42/EC Directive, relative to machinery and that amending Directive 95/16/EC relative to lifts and elevators)

CODICE DOCUMENTO **999.0356.1_REV.0**
DATA **22-02-2021**



UFI FILTERS HYDRAULICS S.P.A.

Via S. Chierico, 24 - 24060 Bolgare BG - Italy
Tel (+39) 035 4493811 - Fax (+39) 035 843743
e-mail info.ufihyd@it.ufifilters.com - www.ufihyd.com

SEDE LEGALE

Via Europa, 26 - Porto Mantovano
Cap. Soc. EUR 384.800,00 i.v. - P. IVA IT 01657800205
R.I.UFF.MN n. 16345 - C.C.I.A.A. MN n. 172926 - n.Mecc.MN008697

UOW-GTC

USE AND MAINTENANCE INSTRUCTION MANUAL



INDEX

1 INTRODUCTION	3	6 PLACEMENT OF THE OIL TRANSFER AND FILTRATION PACKAGE IN THE OPERATIONAL AREA	8
1.1 IDENTIFICATION OF THE DOCUMENT	3	6.1 HANDLING AND POSITIONING OF THE OIL TRANSFER AND FILTRATION PACKAGE	8
1.2 REFERENCE DOCUMENTS	3	6.2 CONNECTION AND DISCONNECTION OF THE HOSES	8
1.3 PURPOSE OF THE DOCUMENT	3	6.3 ELECTRICAL CONNECTION	8
1.4 REFERENCES TO THE REGULATIONS	3	7 CONTROLS	9
1.5 RETENTION OF THIS MANUAL	3	7.1 COMMAND AND CONTROL DEVICES	9
1.6 UPDATES	3	8 USE OF THE OIL TRANSFER AND FILTRATION PACKAGE	9
1.7 OPERATORS	3	8.1 INITIAL CHECKS AND INSPECTIONS	9
1.8 SAFETY WARNINGS	3	8.2 TRANSFER AND FILTRATION CYCLE	9
1.9 SAFETY PRECAUTIONS	4	8.3 TRANSFER AND FILTRATION CYCLE END	9
1.10 LEGIBILITY AND CONSERVATION OF THE RATING PLATES AND OF THE PICTOGRAMS	4	9 MAINTENANCE	10
2 GENERAL INFORMATION	4	9.1 SUBSTITUTION OF THE FILTER ELEMENT	10
2.1 MANUFACTURER IDENTIFICATION DATA	4	9.2 INSPECTION	10
2.2 DESIGNATION OF THE OIL TRANSFER AND FILTRATION PACKAGE	4	9.3 CLEANING OF THE EQUIPMENT	10
2.3 CE DECLARATION OF COMPLIANCE FOR THE OIL TRANSFER AND FILTRATION PACKAGE	4	9.4 EXTRAORDINARY MAINTENANCE	10
2.4 GUARANTEE	4	10 EMERGENCIES	11
3 SPECIFICATIONS FOR THE OIL TRANSFER AND FILTRATION PACKAGE	5	10.1 SPILLS	11
3.1 INTENDED USE	5	10.2 FIRE	11
3.2 DESCRIPTION	5	10.3 EQUIPMENT MALFUNCTIONS	11
3.3 TECHNICAL SPECIFICATIONS, INDICATIONS ON NOISE, VIBRATIONS AND CHEMICAL AGENTS	5	11 BODY PROTECTION	11
3.4 ENVIRONMENTAL CONDITIONS ALLOWED FOR USE	6	11.1 PERSONAL PROTECTIVE EQUIPMENT	11
3.5 CIRCUIT DIAGRAM	6	12 WASTE	11
3.6 HYDRAULIC DIAGRAM	6	12.1 RESIDUE AND COMPONENT WASTE DISPOSAL FOR THE EQUIPMENT	11
4 HAZARDS AND PROTECTIONS	7	ATTACHMENTS	
4.1 PROHIBITED USES	7	DDeclaration of machine compliance	ATTACHMENT 1
4.2 RESIDUAL RISKS	7		
4.3 PROTECTION AND SIGNAL DEVICES	7		
5 TRANSPORT AND STORAGE	8		
5.1 TRANSPORT AND HANDLING	8		
5.2 WAREHOUSING	8		



1 INTRODUCTION

1.1 IDENTIFICATION OF THE DOCUMENT

THE "USE AND MAINTENANCE INSTRUCTION MANUAL FOR THE OIL TRANSFER AND FILTRATION PACKAGE" is an official document issued by UFI Filters Hydraulics S.p.A. and is to be considered an integral part of the same unit.

This manual was originally written in Italian, the only official language for which the manufacturer will be held responsible in the event of non-compliance of the translations.

This document is distinguished by a document code, found on the cover, enabling its identification and reference.

1.2 REFERENCE DOCUMENTS

- Pump specifications
- Electrical motor specifications
- Specifications for the hoses and the fittings
- Specifications for the command panel, cable and electrical power supply plug
- Wiring diagram
- Hydraulic diagram
- Frame drawing
- Oil transfer and filtration package drawing

1.3 PURPOSE OF THE DOCUMENT

This manual, destined for the users of the oil transfer and filtration package, contains all of the information necessary for its proper usage and its regular maintenance. The protection of the health and safety of the operator as well as the proper operation of the equipment depend upon the scrupulous observance and respect for the instructions and the regulations contained in this manual.

1.4 REFERENCES TO THE REGULATIONS

This document has been prepared in compliance with:

- Legislative Decree January 27, 2010, n. 17, Annex I
- Title III, Chapter I and attachments V – VI of the Legislative Decree April 9, 2008 no. 81
- UNI EN ISO 12100 – 1/2: 2009

1.5 RETENTION OF THIS MANUAL

This document must be considered an integral part of the machine unit, it must be kept with the unit in the locations where the machine will be put to use, and it must be maintained integral for the entire service life of the machine.

1.6 UPDATES

Any updates of this document may be transmitted to the owner of the oil transfer and filtration package in single pages, complete, however, with suitable indications enabling the precise insertion of the same.

1.7 OPERATORS

- The operations described in this document, which have been carefully and completely analysed, may be optimally performed by a single operator. Other operators may be required for specific checks and verifications or procedures on the system or machine, object of the filtration and for oil loading or handling of any heavy and bulky containers.
- Operators must possess specific knowledge of the system or the machine, object of the filtration operations and oil loading, of the proper methods for cut off of the hydraulic system network involved in the operation, the proper connection of the hoses to the system on which the procedures are being performed, the proper attachment of the hoses to the containers, the correct procedures for the electrical devices and the characteristics of the fluids that are being processed.
- Operators must be suitably trained so as to be able to handle the performance of any operational procedure that may become necessary for the function and control of the specific operations, the proper evaluation of events that follow one another during the running of operations, the proper cut off of the system or machine object of the filtration operation and oil loading and the proper evaluation of any alarm signals that may intervene during the filtration and oil loading cycle so that the emergency shut down of the oil transfer and filtration package may be executed.

1.8 SAFETY WARNINGS

- Most work-related accidents may be attributed to the failure to observe safety regulations. It is therefore fundamental that anyone who works with the oil transfer and filtration package be thoroughly knowledgeable regarding the regulations found in this manual and that these be respected absolutely.
- The operator who uses the oil transfer and filtration package must be informed and trained; his or her level of training must be suitably verified.
- Before undertaking the initiation of any operations with or the handling of the oil transfer and filtration package, put on the anticipated personal protective equipment (shoes, gloves, and eye protection when necessary).

UOW-GTC

USE AND MAINTENANCE INSTRUCTION MANUAL



- Before initiating any operational activity, check and verify the integrity of: the equipment, the hoses including their specific couplings and fittings, the command panel and the electrical power supply and plug.

1.9 SAFETY PRECAUTIONS

- Handle the oil transfer and filtration package with all due caution, and only on level and suitably resistant flooring. Because it is hazardous, do not handle the oil transfer and filtration package on steeply sloping or irregular surfaces with holes or on those that are not strong enough.
- Always position the oil transfer and filtration package, whether in the operational position or in storage, on perfectly level surfaces with adequate load resistance so as to avoid its accidental overturning.
- The areas where the oil transfer and filtration package is being handled or operated must be properly illuminated. When necessary for and specific applications use supplementary lighting corresponding to the laws in effect.
- The equipment must be positioned so as to enable the

operator to work in complete safety without impeding or limiting the movements necessary for the operations to be performed with any tools that may be needed.

- Placement of the equipment must not obstruct pedestrian walkways, vehicle roadways, or emergency exits. It must not obstruct or slow any procedures or interventions on handling and movement equipment or any emergency equipment.

1.10 LEGIBILITY AND CONSERVATION OF THE RATING PLATES AND PICTOGRAMS

- The rating plates and pictograms must be maintained perfectly legible, in the event that any of these becomes illegible or deteriorated, immediate substitution must be seen to requesting replacements from the manufacturer

2 GENERAL INFORMATION

2.1 MANUFACTURER IDENTIFICATION DATA

Below the oil transfer and filtration package manufacturer's identification information may be found:

- Corporate Name: PLANET FILTERS SPA
- Address: via San Chierico, 24 – 24060 Bolgare BG
- Tel. 0354493811
- Fax. 0354493843

2.2 DESIGNATION OF THE OIL TRANSFER AND FILTRATION PACKAGE

- Name: OIL TRANSFER AND FILTRATION PACKAGE
- Code/model: UOW040M0075A3XX
- Plant/type: 004.0148.2
- Year of Manufacture: SEE MACHINE RATING PLATE
- "CE" marking: compliant with Attachment III of the Leg. Dec. No. 17/2010

2.3 "CE" DECLARATION OF COMPLIANCE FOR THE OIL TRANSFER AND FILTRATION PACKAGE

The declaration of compliance for the oil transfer and filtration package, prepared pursuant to Attachment II A of the Legislative Decree of January 27, 2010 no. 17, is provided in a copy in Attachment 1 of this document.

2.4 GUARANTEE

- The oil transfer and filtration package undergo a rigorous test inspection before shipment.
- The equipment subject of this document is guaranteed for 12 months beginning from the date of delivery, against manufacturing defects under normal operational and maintenance conditions.



3 SPECIFICATIONS FOR THE OIL TRANSFER AND FILTRATION PACKAGE

3.1 INTENDED USE

The oil transfer and filtration package is used for the oil transfer, filtration and suction from hydraulic systems. It is equipped with a filter, located on the delivery circuit, which is provided with a visual clogging indicator.

The oil transfer and filtration package may filter and transfer the following fluids:

- Mineral based hydraulic oil: HH – HL – HM – HR – HV – HG (according to ISO 6743-4)

3.2 DESCRIPTION

The oil transfer and filtration package is made up of:

- Frame: fabricated in a welded metal tubular structure, provided with wheels for manual handling.
- Suction and delivery devices: made up of an electrical motor coupled directly to the pump for the handling of the fluid to be filtered.
- Filtration device: not supplied
- Hoses for suction and delivery: these are made of PVC with steel wire spiral and suitably coupled to the suction and pressure devices
- Controls: buttons for the starting and stopping of the machine, complete with overload and short circuit protection devices, an emergency stop button, and a plug for electrical power supply connection.

3.3 TECHNICAL SPECIFICATIONS, INDICATIONS ON NOISE, VIBRATIONS AND CHEMICAL AGENTS

In the following table the technical specifications and other information of interest regarding the oil transfer and filtration package may be found.

TECHNICAL SPECIFICATIONS	DEFINITIONS/INFORMATION
Operation	Electrical
Installed Power	0.75KW
Electrical power supply voltage	Single phase 230V
Electrical Motor	4 pole, type B3B5
Dimensions (LxDxH)	700x400x1200
Weight	65 kg
Maximum operational pressure	10 bar
Maximum pump flow rate	40 L/min
Viscosity	From 30 to 150 cSt
Protection Grade of the motor, control panel and electrical power supply plug	IP 54
Locations with explosion and fire hazard	Prohibited use of the oil transfer and filtration package
Noise emissions	78.6 dB(A)
Vibrations	During operation of the equipment, the operator checks on the operational cycle and acts only on the start and stop buttons.
Chemical agents	During operation of the unit there is no exposure to the presence of vapours or fumes from the fluid being siphoned and filtered.

UOW-GTC

USE AND MAINTENANCE INSTRUCTION MANUAL



3.4 ENVIRONMENTAL CONDITIONS ALLOWED FOR USE

The environment where the oil transfer and filtration package is being operated must be suitably illuminated and aerated. The ideal environmental conditions for its use are found below:

- Environmental temperature must be between 5°C and 45°C.
- Relative humidity must not exceed 70%.
- Within the operational environment the concentration of hazardous substances that may cause a risk of explosion or ignition must not occur.
- Within the operational environment the formation of dust or spray of the liquid must be compliant with the protection grade (seal of the housings and the storage cases) against the penetration of solids and liquids established for the motor, the control panel and the electrical power supply plug, which has been identified as IP 54.
- The environment must not have corrosion hazards present.

3.5 CIRCUIT DIAGRAM

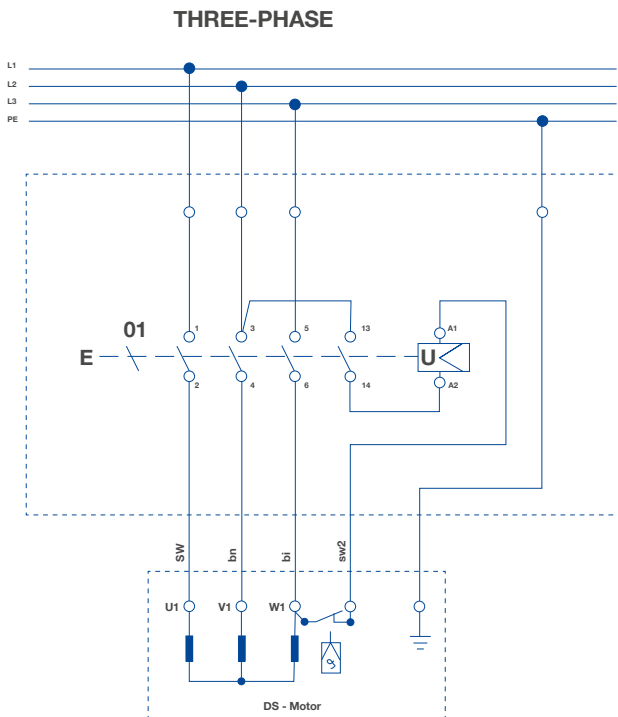

3.6 HYDRAULICS DIAGRAM

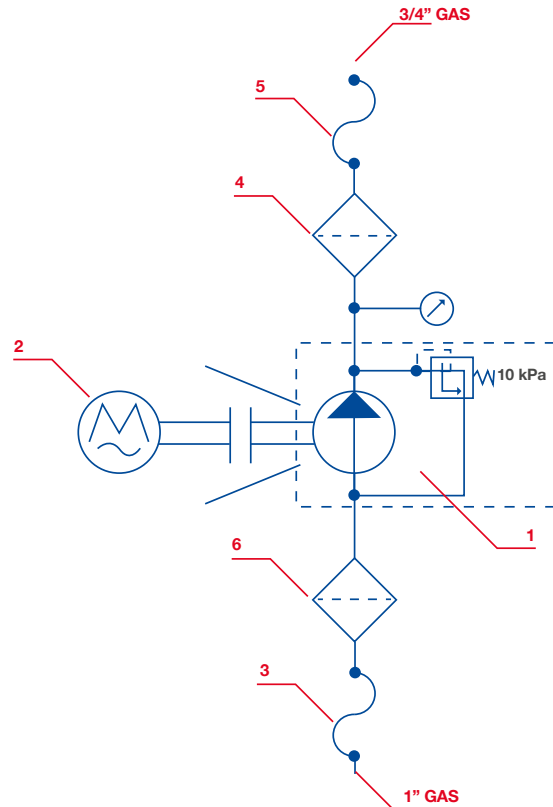

Article	Description of the article
1	ALP2-D-40 VM-E0/10 Gear pump
2	HP1 4P B3B5 230V 50/60Hz Electrical Motor
3	PVC HOSE WITH STEEL SPIRAL DN 1" L = 2.5m Suction hose
4	004.0142.2 Delivery filter
5	PVC HOSE WITH STEEL SPIRAL DN 20 L = 2.5m Delivery hose
6	VA 1" Y suction filter



4 HAZARDS AND PROTECTIONS

4.1 PROHIBITED USES

- Any different use of the oil transfer and filtration package from that established in this evaluation (including the type of fluid to be filtered) is to be considered improper, and not indicated in that any consequent risks cannot be evaluated. Therefore, the manufacturer is exonerated from any responsibility derived from the lack of observance of this prohibition. The oil transfer and filtration package must be used only for the purpose expressly indicated in this document.
- In particular use of the oil transfer and filtration package is prohibited:
 - In locations with explosion and fire hazards;
 - In locations with the presence of solids and liquids that are not compatible with the protection grade found in the table referred to in point 3.3 TECHNICAL SPECIFICATIONS;
 - In locations where the electrical voltage is not compatible with that of the oil transfer and filtration package, the value of which may be found in the table referred to in point 3.3 TECHNICAL SPECIFICATIONS
 - In the presence of the control panel, start button, electrical supply cord or plug, any of the hoses or their fittings and couplings that are no longer integral;
 - In the presence of any damage to the same equipment;
 - In the presence of an electrical power supply that is not compliant to the regulations in force: lacking a breaker upstream, a differential current device, or a lines ground connection. It is the responsibility of the user to perform the electrical connections compliant to the safety standards in effect
 - In the presence of a support surface that is not perfectly level and sufficiently strong in that the equipment must always be used in a vertical position and in conditions of perfect stability.

4.2 RESIDUAL RISKS

During the design phase a careful analysis of the risks that could be incurred by operators assigned to using and maintaining the oil transfer and filtration package was performed, therefore all of the precautions possible and necessary to make the machine under discussion safe and reliable have been taken. From the analysis performed no particular conditions of residual risk were brought to light.

4.3 PROTECTIONS AND SIGNAL DEVICES

The start button has been perfectly sealed.

The electrical motor fan has been protected with a suitable housing attached with screws. To loosen or tighten the screws a specific hand tool must be used.

The oil transfer and filtration package has been equipped with a device, which in case of a power failure the equipment will not re-start, not even accidentally. To re-start the equipment, it is necessary to push the green (start) button again.

Fouling of the filter is visualised:

- By the manometer on the filter; the graduated scale on the manometer is in two colours: red and green. Red indicates the clogging of the filter element (green indicates regular filtering). When the indicator on the instrument goes into the red zone, the operator must stop the equipment in a timely manner, using the emergency stop button located on the start panel. This case necessitates the substitution of the clogged filtration element.

5 TRANSPORT AND STORAGE

5.1 TRANSPORT AND HANDLING

The oil transfer and filtration package is not normally disassembled for transport.

So as to protect the oil transfer and filtration package suitably and enable its safe transport and handling, a packing structure has been realised for it with suitable specifications regarding its form and strength. The packaging, wood platform and supports, insure the stability of the equipment, which must always be in a vertical position.

During shipping and handling, the packing crate must not ever be tilted or turned over. The stability of the packing crate must be guaranteed during shipping.

For handling (hoisting, lowering and movement on a level surface) of the crate, use suitable equipment with a load limit not less than 100 kg.

- Movement with a forklift truck is to be performed only when the equipment is packed in its crate. In any case the stability of the equipment must be guaranteed with appropriate equipment and devices.
- Hoisting with a winch: sling the equipment, hooking the artificial fibre sling on the first cross member of the trolley frame in two points equidistant from the centre point of the

trolley, so that the equipment will be perfectly balanced. Perform all movement smoothly without jerking and using the necessary attention and prudence.

- Handling with a lift: make sure that the equipment is stable and if necessary tie it down so as to avoid any hazardous shifting.

5.2 WAREHOUSING

The oil transfer and filtration package does not guarantee protection from atmospheric agents. In particular it is highly recommended to not permit the unit packaged or not to remain for an extended duration in a humid, saline or corrosive environment.

It is recommended that the equipment be stored indoors, in a dry environment with the temperature between -15°C and 60°C, with the humidity no greater than 70 % and not exposed to either a saline or corrosive atmosphere. Avoid prolonged and direct exposure to sunlight so as to conserve the function of the rubber hoses.

6 PLACEMENTS OF THE OIL TRANSFER AND FILTRATION PACKAGE

6.1 HANDLING AND POSITIONING OF THE OIL TRANSFER AND FILTRATION PACKAGE

The oil transfer and filtration package must be maintained in any event in a vertical position.

During handling of the unit it should be tilted slightly toward the operator; it must be pushed, not pulled. All movements must be carried out grasping the specific handle whilst avoiding abrupt movements.

In the work position of the equipment, the hoses, the electrical power supply cable and any oil containers must be arranged so as to avoid any type of risk.

For furthermore complete information refer to point 1.9 SAFETY PRECAUTIONS.

6.2 CONNECTION AND DISCONNECTION OF THE HOSES

Before any type of connection, check and verify the integrity of the hoses and of their connection couplings. If these are not in perfect condition, they must be substituted.

Connect these to the hydraulic system or position the hoses in oil containers in a manner coherent with the job at hand: keep in mind that the larger diameter hose corresponds to the

suction, whilst the smaller hose is the delivery side.

Oil containers: before initiating operations make sure that these are securely stabilised and that their capacity is suitable for the work to be performed. Position the hoses in the containers and set their position so that any hazardous oscillations are prevented.

6.3 ELECTRICAL CONNECTION

Before any type of connection, check and verify the integrity of the electrical power supply cable and the plug. If these are not in perfect condition, they must be substituted.

Before making any electrical connections, verify that the electrical mains voltage is compatible with that of the oil transfer and filtration package; this value may be found in the table referred to in point 3.3 TECHNICAL SPECIFICATIONS

Before connecting to the outlet, make sure that the start switch, both for start and stop, is in its open position.

7 CONTROL DEVICES

7.1 COMMAND AND CONTROL DEVICES

The buttons for start and stop of the oil transfer and filtration packages are located:

- On the start panel: to start the unit it is necessary to press the green button; to stop it press the red button.

The emergency stop button is located:

- On the start panel. This button is to be used only in case of hazard and not as the normal stop button for the equipment. The emergency stop button works merely by pressing it.

8 USE OF THE OIL TRANSFER AND FILTRATION PACKAGE

8.1 INITIAL CHECKS AND INSPECTIONS

Before starting the operational cycle verify:

- The stability of the equipment and its correct positioning;
- The proper connection of the hoses to the hydraulic system or their proper positioning in the oil containers (remember that the larger diameter hose corresponds to the suction, whilst the smaller hose is the delivery side);
- That the hoses have no kinks, or reductions due to crushing or foreign objects
- That into the oil container can discharge the fluid at atmospheric pressure;
- That the pump turns in a clockwise direction, as indicated by the direction of the arrow found on the motor. If it turns in the opposite direction, stop the unit immediately and request the intervention of qualified personnel so as to invert the electrical power connection wiring at the plug.

8.2 OIL TRANSFER AND FILTRATION CYCLE

Start up the equipment by pressing the green button. Check and verify the proper function of the equipment. Verify that there are no oil leaks. Make sure that in the suction hose there is a constant flow of oil and that the pump is not subject to cavitation.

Keep the manometer under close observation; the graduated scale in red indicates clogging of the filter element.

8.3 OIL TRANSFER AND FILTRATION CYCLE END

Stop the equipment by pressing the red button:

- Remove the plug from the outlet on the start panel and replace the cable in its initial position.

Make sure that the hoses have been completely emptied. If there are residues of oil in them, pour into suitable containers, then coil the hoses on the same unit.

Transfer the equipment and oil containers to their storage area.

9 MAINTENANCE

9.1 SUBSTITUTION OF THE FILTER ELEMENT

Before proceeding with the substitution of the filtration elements, it is necessary to disconnect the electrical power supply plug, disconnect the hoses from the hydraulic system or from the oil containers so as to avoid hazards of accidental start-up of the equipment, pressure in the filter housing or accidental spills.

Unscrew the four fastening nuts to open the filter cover, proceed with the extraction of the filter element.

The oil that is in the filter element is contaminated and therefore should not be poured into the filter so as to not contaminate the oil already filtered. This oil should be poured into a suitable waste oil container.



Unscrew the lower fastening nut, slide out the spacer and then the contaminated filter element.

Assemble the new, clean filter element, insert the spacer and tighten the fastening nut down tight.

Slide the element and its support into the filter housing, close the filter cover and tighten the 4 fastening nuts back down.



During these operations it is necessary to pay particular attention and take precautions to avoid any accidental spills of oil. Make sure that any spills are cleaned appropriately. It is preferable to perform these procedures over a pan for the collection of any possible spills.

9.2 INSPECTION

Periodically, proceed with the visual check of the integrity of the components of the oil transfer and filtration package:

- Frame, electrical motor and pump, hoses and their specific coupling connections, start panel and the manometer. Indicate any faults or anomalies encountered.

Periodically, verify the stability of the equipment, indicate any inadequacies encountered.

Every quarter, check and verify the seal of the hoses.

Twice a year, with qualified personnel: verify the electrical components, checking the integrity of the connection plug.

9.3 CLEANING OF THE EQUIPMENT

At the end of each work cycle, remove any traces of oil that may be present. Periodically clean the entire equipment.

9.4 EXTRAORDINARY MAINTENANCE

For any procedures regarding the motor, the pump and the check valve, it is necessary to address the manufacturer.

10 EMERGENCIES

10.1 SPILLS

After any accidental spills, if necessary, delimit the area involved in a suitable manner so that unauthorised personnel and vehicles do not enter. Clean the spill area completely, using, if necessary suitable absorbents.

10.2 FIRE

In the work area, guarantee the presence of suitable fire extinguishers for the fluid being filtered and a number suitable for the risk.

10.3 EQUIPMENT MALFUNCTIONS

Stop the work cycle of the equipment in a timely manner using the emergency stop button:

- Found on the start panel.

11 BODY PROTECTION

11.1 INDIVIDUAL SAFETY DEVICES

For safe use of the oil transfer and filtration package, subject of this document, operators should wear the following personal protective equipment:

- Safety shoes with steel toe;
- Five finger safety gloves against physical injury
- Five finger safety gloves against chemical burns
- Eye protection mask
- Protective smock against chemical burns to be evaluated case by case.

Naturally, the personal protective equipment indicated for the specific workplace where one works is to be adopted: for example, protective hard hat against head injuries, ear protectors or muffs for noise, etc.

12 WASTE

12.1 EQUIPMENT RESIDUE AND COMPONENT WASTE DISPOSAL

Disposal of the contaminated filter element and of any fluid present in the delivery and suction lines of the equipment or in the same equipment must come about with respect for the regulations in effect, in the same manner as for storage and for disposal of any accidental spills and relative absorbent materials.

For the same oil transfer and filtration package the different components must be separated according to their classifications established by the regulations in effect, to then proceed with their disposal with respect for the same regulations.

ATTACHMENT 1

Declaration of machine compliance

