

FILTRATION IN BRIEF

Contamination control in hydraulic systems

INTRODUCTION

Contamination Control in the hydraulic systems is a very wide and complex matter; the following is just a short summary. Our Customer Service is at your disposal for any further information.

The function of the fluid in the hydraulic systems is transmitting forces and motion.

In view of a reliable and efficient operation of the system, it is very important to select the fluid considering the requirements of the system and the specific working conditions (working pressure, environment temperature, location of the system, etc.). Depending on the required features (viscosity, lubricant capacity, anti-wear protection, density, resistance to ageing and to thermal solicitations, materials compatibility, etc.), the proper oil can be selected among a number of mineral oils (the most popular), synthetic fluids, water based fluids, environmental friendly fluids, etc.

All the hydraulic fluids are classified according to international standards.

Solid contamination is recognized as the main reason for malfunctioning, failures and early decay in hydraulic systems; **it is impossible to eliminate completely it, but it can be well kept under control with proper devices (filters).**

No matter which fluid is used, it must be kept at the contamination level required by the most sensitive component used on the system.

HOW THE CONTAMINATION IS MEASURED

The contamination level is measured by counting the number of particles of a certain dimension per unit of volume of the fluid; this number is then classified in Contamination Classes, according to international standards.

Measuring is made with Automatic Particle Counters that can make the analysis on line (through sampling connectors put on the system for this purpose) or from sampling bottles.

Measurements and sampling of the fluid must be done according to the specific ISO norms, to attest their validity.

The most popular standard for Contamination Classes in the hydraulic systems is ISO 4406:1999; the standard NAS 1638 (under revision) is also quite used.

CONTAMINATION CLASSES ACCORDING TO ISO 4406:1999

The Contamination Class according to this standard is described by 3 numbers indicating the number of particles per 100 ml of fluid having bigger size than 4, 6 e 14 $\mu\text{m}_{(c)}$ respectively.

ISO Code	Number of particles per 100 ml	
	more than	up to
22	2,000,000	4,000,000
21	1,000,000	2,000,000
20	500,000	1,000,000
19	250,000	500,000
18	130,000	250,000
17	64,000	130,000
16	32,000	64,000
15	16,000	32,000
14	8,000	16,000
13	4,000	8,000
12	2,000	4,000
11	1,000	2,000
10	500	1,000
9	250	500
8	130	250

E.g.:



ISO Code	21/18/15 :	21 \Rightarrow \geq 4 $\mu\text{m}_{(c)}$	18 \Rightarrow \geq 6 $\mu\text{m}_{(c)}$	15 \Rightarrow \geq 14 $\mu\text{m}_{(c)}$
----------	-------------------	--	--	---

The above Contamination Class describes a fluid containing:

- between 1,000,000 and 2,000,000 particles \geq 4 $\mu\text{m}_{(c)}$ per 100 ml
- between 130,000 and 250,000 particles \geq 6 $\mu\text{m}_{(c)}$ per 100 ml
- between 16,000 and 32,000 particles \geq 14 $\mu\text{m}_{(c)}$ per 100 ml

FILTRATION IN BRIEF

Contamination control in hydraulic systems

FILTERS AND FILTER MEDIA

All the hydraulic systems have an initial solid contamination, tending to increase during operation due to components wear, ingress from seals, etc. For this reason it is necessary to use filters that retain the contaminant and allow to reach and maintain the required contamination class.

Depending on their location into the system, the most common filter types are:

- **return filters**, downstream from all the components, filtering the oil before it returns into the tank. Their function is keeping the required contamination level inside the tank (indirect protection of the components) and must be sized to have a high dirt holding capacity (i.e. a long life). They usually have filter elements by glassfiber (absolute filtration, $\beta_x \geq 75$) or by cellulose (nominal filtration, $\beta_x \geq 2$).
- **in line filters**, on the pressure line, protecting directly one or more components, ensuring they are fed with oil having the proper contamination class. They usually have filter elements by glassfiber (absolute filtration, $\beta_x \geq 75$), sometime by cellulose (nominal filtration, $\beta_x \geq 2$).
- **suction filters**, on the suction line, protecting the pump from possible coarse contamination. They usually have filter elements by metal wire mesh (geometric filtration) and must be sized properly, to avoid any possible pump cavitation.

Good **air filters** (breathers), filtering the air sucked into the tank when the oil goes to the actuators, must be used to avoid contaminant ingress from the environment.

When a very low contamination class is required (i.e. very good cleanliness) it can be necessary to use a **off-line filter**, that operates at steady flow rate and pressure, thus getting the highest filtration efficiency.

Even the new oil has always a certain solid contamination, so it is a good rule to make any filling or refilling of the system by using a **filtration unit**.

HOW TO MEASURE THE FILTRATION EFFICIENCY

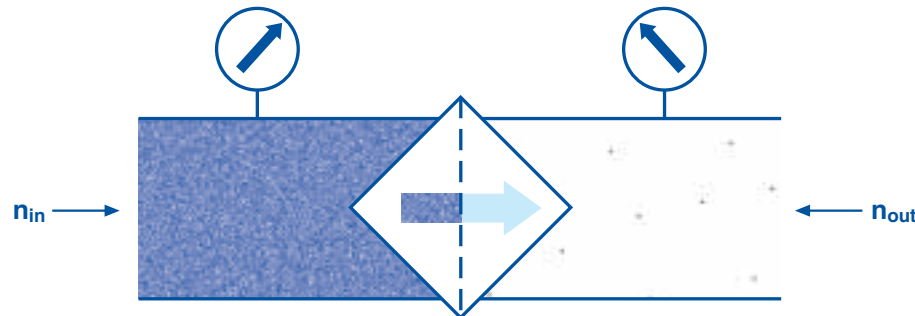

Beta ratio:

$$\beta_x = (n_{in} = X \mu\text{m}) : (n_{out} = X \mu\text{m})$$

where "n" is the number of particles = x mm upstream and downstream from the filter.

E.g. if you have 100,000 particles = 10 μm upstream and 1,000 particles downstream:

$$\beta_{10} = 100,000 : 1,000 = 100$$

Filtration efficiency η (%):

$$\eta = 100 - (100 : \beta)$$

i.e.

$$\beta_x = 2 \text{ means } \eta = 50.00 \%$$

$$\beta_x = 20 \text{ means } \eta = 95.00 \%$$

$$\beta_x = 75 \text{ means } \eta = 98.67 \%$$

$$\beta_x = 100 \text{ means } \eta = 99.00 \%$$

$$\beta_x = 200 \text{ means } \eta = 99.50 \%$$

$$\beta_x = 1.000 \text{ means } \eta = 99.90 \%$$

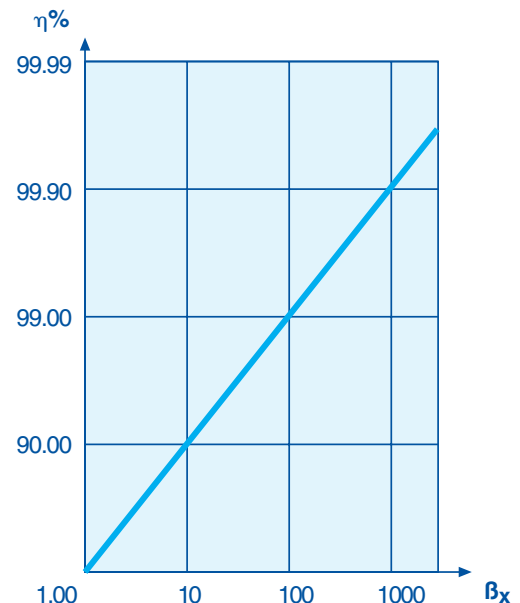

FILTRATION IN BRIEF

Contamination control in hydraulic systems

FILTER MEDIA AND CONTAMINATION CLASSES

Each hydraulic components manufacturer specifies the contamination class required for the best performance and life of their components.

To achieve the required contamination class, the proper UFI filter media must be chosen according to this table:

Typical application	Aeronautic, test rigs.	Aeronautic, ind. robotics	Ind. robotics, precision machine tools	High reliability ind. machines, Hydrostatic transmissions	Industrial machines, earth moving machines	Mobile machines	Machines for heavy industry	Machines for agriculture systems not continuous service
Pumps and / or motors		Piston, variable >3000 psi	Piston, variable <3000 psi Vane, variable >2100 psi	Pist./vane, variable <2100 psi Pist./vane, fixed >2100 psi	Pistons, fixed <2100 psi Vane, fixed >2100 psi	Vane, fixed gear >2100 psi	Vane, fixed gear <2100 psi	Vane, fixed gear <2100 psi
Valves	Servovalves >3000 psi	Servovalves <3000 psi Proportional >3000 psi	Proportional <3000 psi Cartridge >2100 psi	Cartridge <2100 psi	Solenoid >3000 psi	Solenoid <3000 psi	Solenoid >2100 psi	Solenoid >2100 psi
Contamination class NAS 1638	4	5	6	7	8	9	10	11
Contamination class ISO 4406 - 1999	15/13/10	16/14/11	17/15/12	18/16/13	19/17/14	20/18/15	21/19/16	22/20/17
Recommended UFI filter media	FA $\beta_{33} > 200$	FA - FB $\beta_{33} > 200$ $\beta_{6} > 200$	FB $\beta_{6} > 200$	FB - FC $\beta_{6} > 200$ $\beta_{12} > 200$	FC - FD $\beta_{12} > 200$ $\beta_{25} > 200$	FD $\beta_{25} > 200$	FD - CC $\beta_{25} > 200$ $\beta_{10} > 2$	CC $\beta_{10} > 2$

NEW REFERENCES FOR THE "BETA" RATIO

Since 1999 the new standard ISO 16889 has replaced the former ISO 4572 concerning the Multi-Pass test, measuring the Beta value of a filter element.

The new standard uses the new test dust ISO MTD instead of the ACFTD formerly used, both in the Multi-Pass test rigs both for the calibration of the automatic particle counters.

In the ISO 16889 the particles sizes are measured in a different way than in the ISO 4572.

To avoid any confusion, when micron are measured according to ISO 11171 they are indicated as $\mu\text{m}_{(c)}$.

The 3 reference sizes to state the contamination class (according to ISO 4406-1999) are now :

4 $\mu\text{m}_{(c)}$ (it was 2 μm in the former standard)

6 $\mu\text{m}_{(c)}$ (it was 5 μm in the former standard)

14 $\mu\text{m}_{(c)}$ (it was 15 μm in the former standard)

Depending on the measuring method, the reference Beta values of the UFI filter media are as follows:

UFI media	$\beta_x > 200$ (ISO 4572)	$\beta_{x(c)} > 1000$ (ISO 16889)
FA	3 μm	5 $\mu\text{m}_{(c)}$
FB	6 μm	7 $\mu\text{m}_{(c)}$
FC	12 μm	12 $\mu\text{m}_{(c)}$
FD	25 μm	21 $\mu\text{m}_{(c)}$

N.B. The contamination classes achieved (i.e. the performances on the field) as well as the pressure drop values remain unchanged.

The technical data reported on our catalogue still refer to the ISO 4572 standard, while waiting for all the new test reports according to the ISO 16889.

FILTRATION IN BRIEF

Contamination control in hydraulic systems

REAL FLOW RATE THROUGH THE FILTER

In order to size properly the filter, it is essential to calculate the REAL flow rate of the oil passing through it:

- in **suction and pressure filters** the flow rate is usually the same than the pump delivery (with the exception of the FPD01 and 12 series, where the flow rate is just the one required by the pilot valve)
- in **return filters** it is necessary to calculate the maximum possible flow rate, taking in account any possible additional return line, cylinder and accumulator. If such data are unknown, as a good rule a flow rate at least $2 \div 2.5$ times the pump delivery should be considered.

Filter element life is significantly effected by the pollution level at the machine location and by the maintenance level of the machine. Considering these parameters the actual flow rate should be multiplied by the following "Environmental Factor":

ENVIRONMENTAL FACTOR			
System maintenance level	Environment contamination level		
	LOW	MEDIUM	HIGH
<ul style="list-style-type: none"> • tank with good protection, efficient air breathers • few actuators, with very good protection from contaminant ingress • frequent monitoring of filter conditions 	1.0	1.0	1.3
<ul style="list-style-type: none"> • tank with protection, good air breathers • many actuators, with good protection from contaminant ingress • scheduled monitoring of filter conditions 	1.0	1.5	1.7
<ul style="list-style-type: none"> • tank with poor protection • many actuators, with low protection from contaminant ingresses • random monitoring of filter conditions 	1.3	2.0	2.3
	F. i. system located in climatized room	F. i. system located in industrial building	F. i. system located in hostile environment (foundry, wood working machines, mobile machines)

PRESSURE DROP (Δp) (according to ISO 3968)

After having stated the filter media and the REAL flow rate, the filter must be chosen from the "flow rate tables" on the catalogue. The values shown there take in account the pressure drop Δp met by the fluid passing through the filter, that must be within a certain value.

In practice, the "assembly Δp " (Δp filter housing + Δp filter element) with clean filter element should be

- **0.4 psi** (0.03 bar)
max for suction filters
- **5 ÷ 7 psi** (0.35 ÷ 0.5 bar)
max for pressure filters < 160 psi (110 bar)
- **5 ÷ 7 psi** (0.35 ÷ 0.5 bar)
max for return filters
- **12 ÷ 17 psi** (0.80 ÷ 1.2 bar)
max for pressure filters > 160 psi (110 bar)

Lower is the initial pressure drop, better is the filter efficiency and longer filter element service life.

N.B. The flow rate values given in the tables are referred to mineral oil with viscosity "V" di 30 cSt and density "ps" = 0.9. When using oils with different features, the following correction factors must be applied at the Δp_0 values obtained on the curves:

FILTER HOUSING: the pressure drop is directly proportional to the oil density "ps", so in case you have $ps_1 \neq 0.9$ → $\Delta p_1 = (\Delta p_0 \times ps_1) : 0.9$

FILTER ELEMENT: the pressure drop through the filter element varies in function of the oil viscosity, so in case you have a viscosity V_1 (cSt) different from cSt :

- for oil viscosity ≤ 150 cSt → $\Delta p_1 = \Delta p_0 \times (V_1 : 30)$
- for oil viscosity > 150 cSt → $\Delta p_1 = \Delta p_0 \times [V_1 : 30 + \sqrt{(V_1 : 30)}] : 2$

Some fluids have **filterability problems** (difficulty in passing through a "multilayer" (glassfiber) filter media). In such cases a **correction factor** must be considered when sizing the filter: this factor must be verified with the filter manufacturing, specifying all the features of the fluid.

FILTRATION IN BRIEF

Contamination control in hydraulic systems

CLOGGING INDICATOR

During the system operation, the pressure drop through the filter increases as the element clogs, due to the contaminant retained. The filter element must be replaced when clogged and anyway before the pressure drop reaches the bypass valve set value.





For this reason it **is recommended a clogging indicator on the filter. It can give a visual or electrical indication and must have a set value lower than the bypass valve set value**, to get an exact indication of the right time for filter element replacement.

On **return** and **low pressure filters** the clogging indicator can be a **pressure gauge** or a **pressure switch**, measuring the pressure upstream the filter.

On some return filters and on **high pressure filters**, the clogging indicator can be of **differential** type: measuring the pressure upstream and downstream the filter and activating a signal when the differential pressure reaches the set value.

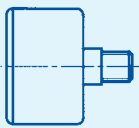
On **suction filters** the clogging indicator is a **vacuum gauge** or a **vacuum switch**, measuring the depressure downstream from the filter.

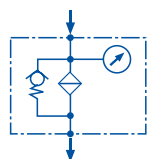
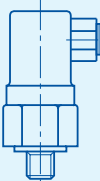
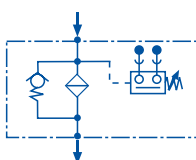
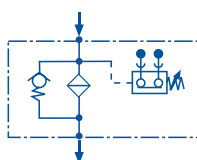
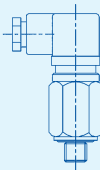
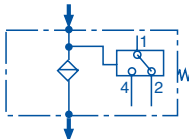
All the **“TANK CARE”** filters have the port for the indicator as a standard feature; if the filter is ordered without indicator the port is plugged with a removeable plug allowing the indicator to be added easily at any time.

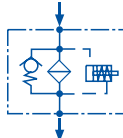
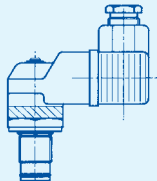
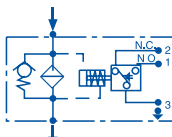
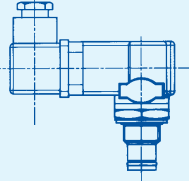
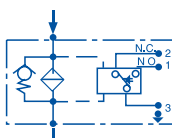



 <p>Series 30, rear connection, usable on FRA - FRB - FRC FRF - FRH</p>	 <p>Series 32, bottom connection, usable on FRA</p>	 <p>PRESSURE GAUGE (visual indicator) scale 0 - 90 psi (0 - 6 bar) Gives a visual indication of the pressure drop across the filter; the element must be replaced when the operating pressure drop reaches 22 psi (1.5 bar).</p>
 <p>Series 80, (N.O. contacts) & series 81, (N.C. contacts) usable on FRA - FRB - FRC - FRH Series 86 & 87 usable on FRB Series 84 & 85 usable on FRF</p>	 	<p>PRESSURE SWITCH (electrical indicator) Activates an electrical contact when the set value is reached, signaling the need for element replacement.</p>
 <p>Series P1 (SPDT), usable on FRA-FRB-FRC-FRH Series P6 (SPDT), usable on FRB</p>		<p>PRESSURE SWITCH (electrical) Activates an electrical contact when the set value is reached, signaling the need for element replacement.</p>
 <p>Series 50 & series 51, usable on FRD - FRF</p>		<p>DIFFERENTIAL INDICATOR (visual) Measures the pressure drop across the filter and gives a visual indication (a green bar switches to red) when the differential pressure reaches the set value, signaling the need for element replacement.</p>
 <p>Series 70 & series 71, usable on FRD - FRF</p>		<p>DIFFERENTIAL INDICATOR (visual & electrical) Measures the pressure drop across the filter and gives a visual indication (a green bar switches to red) plus simultaneously activates an electrical contact when the differential pressure reaches the set value, signaling the need for element replacement.</p>
 <p>Series 60 - 61 & series T0 - T1 usable on FRD - FRF</p>		<p>DIFFERENTIAL INDICATOR (electrical) Measures the pressure drop across the filter and activates an electrical contact when the differential pressure reaches the set value, signaling the need for element replacement. The series “T” includes a thermostat allowing the signal to be activated only when the temperature of 30°C is reached, thus avoiding false alarm in case of cold start.</p>

FILTRATION IN BRIEF



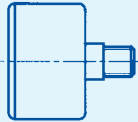

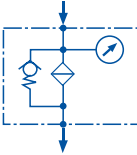
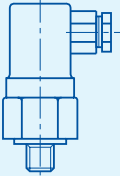
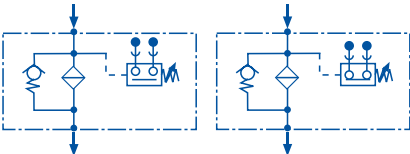
Contamination control in hydraulic systems

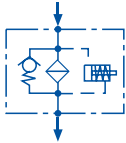
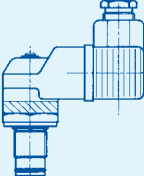
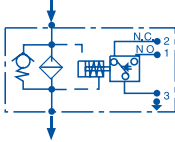
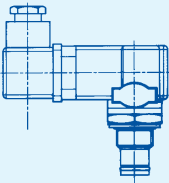
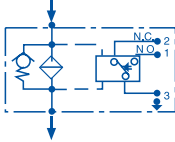
CLOGGING INDICATOR

All the "COMPO CARE" filters have the port for the indicator as a standard feature; if the filter is ordered without indicator the port is plugged with a removeable plug allowing the indicator to be added easily at any time.

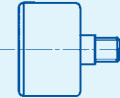
 <p>Series 31, rear connection, usable on FPE - FPF - FPH</p>	 <p>Series 33, bottom connection</p>	 <p>PRESSURE GAUGE (visual indicator) scale 0 -175 psi (0-12 bar) Gives a visual indication of the pressure upstream the filter; the element must be replaced when the pressure value exceeds of 22 psi (1.5 bar) the pressure value with clean element.</p>
 <p>Serie 80, (N.O. contacts) & serie 81, (N.C. contacts) usable on FPE - FPF - FPH</p>	 <p>PRESSURE SWITCH (electrical indicator) Activates an electrical contact when the set value 22 psi (1.5 bar) is reached, signaling the need for element replacement; for this reason the use of this indicator is recommended only for applications where the filter outlet is directly connected to the reservoir.</p>	
 <p>Series 50, usable on FPE3 & 4-FPF3 & 4 Series 52-53, usable on FPA-FPD FPL - FPM Series K2-K3, usable on FPB</p>	 <p>DIFFERENTIAL INDICATOR (visual) Measures the pressure drop across the filter and gives a visual indication (a green bar switches to red) when the differential pressure reaches the set value, signaling the need for element replacement.</p>	
 <p>Series 70, usable on FPE3 & 4 - FPF3 & 4 Series 72-73, usable on FPA-FPD-FPL - FPM Series Y2-Y3, usable on FPB</p>	 <p>DIFFERENTIAL INDICATOR (visual & electrical) Measures the pressure drop across the filter and gives a visual indication (a green bar switches to red) plus simultaneously activates an electrical contact when the differential pressure reaches the set value, signaling the need for element replacement.</p>	
 <p>Serie 60& T0 usable on FPE3 & 4 - FPF3 & 4 Series 62 - 63 & series T2 - T3 usable on FPA FPD - FPL - FPM</p>	 <p>DIFFERENTIAL INDICATOR (electrical) Measures the pressure drop across the filter and activates an electrical contact when the differential pressure reaches the set value, signaling the need for element replacement. The series "T" includes a thermostat allowing the signal to be activated only when the temperature of 30°C is reached, thus avoiding false alarm in case of cold start.</p>	

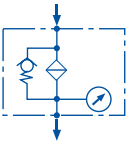
The "PUMP CARE" filters have the port for the indicator as a standard feature; if the filter is ordered without indicator the port is plugged with a removeable plug allowing the indicator to be added easily at any time.

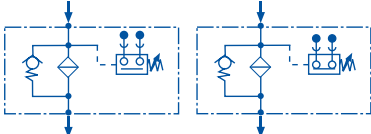
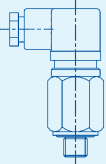
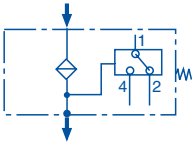
 <p>Series 10, rear connection, usable on FSC - FSE - FSF</p>	 <p>Series 11, bottom connection, FSD</p>	 <p>VACUUM GAUGE (visual indicator) scale 0 ÷ -15 psi (0 ÷ -1 bar) Gives a visual indication of the pressure drop across the filter; the element must be replaced when the operating pressure drop reaches 4 psi (0.3 bar)</p>
 <p>Series 90, (N.O. contacts) & serie 92, (N.C. contacts) usable on FSC - FSD - FSE - FSF</p>	 <p>VACUUM SWITCH (electrical indicator) Activates an electrical contact when the set value 4 psi (0.3 bar) is reached, signaling the need for element replacement.</p>	
 <p>Series 91 & Series L1 (SPDT), usable on FSC - FSD - FSE - FSF</p>	 <p>VACUUM SWITCH (electrical indicator) Activates an electrical contact when the set value 4 psi (0.3 bar) is reached, signaling the need for element replacement.</p>	

UFI Universal Filter International - Hydraulic Division: 9337 Ravenna Road, Unit G - Twinsburg, OH 44087
Phone (330) 4051800 - Fax (330) 4051801 - E-mail: ufilter@uhilt.com

UFI HYDRAULIC DIVISION - PLANET FILTERS S.p.A.
via S.Chierico, 24 - 24060 Bolgare BG - Tel. 035 4493831 - Fax 035 843743
e-mail: info@ufilter.it - http://www.ufilter.com

COMPANY
WITH QUALITY SYSTEM
CERTIFIED BY DNV
=ISO 9001/2000=

COMPANY WITH
ENVIRONMENTAL MANAGEMENT
SYSTEM CERTIFIED BY DNV
=ISO 14001=