



OFF-LINE FILTERS

OF



MATERIALS

Head and covers:
Aluminium alloy

Bowl:
Steel

Element Holder:
Polyamide OF24
Aluminium Alloy OF3+ and OF4+

Seals:
NBR Nitrile
FKM Fluoroelastomer on request

Indicator housing:
Brass

PRESSURE (ISO 10771-1:2002)

Max working:
1 MPa (10 bar)

Test:
1,5 MPa (15 bar)

Bursting:
3 MPa (30 bar)

Collapse, differential
for the filter element: 1 MPa (10 bar)

BYPASS VALVE

Setting:
150 kPa (1,5 bar) \pm 10%

WORKING TEMPERATURE

From -25° to +110° C

COMPATIBILITY (ISO 2943:1999)

Full with fluids: HH-HL-HM-HV-HTG
(according to ISO 6743/4)
For fluids different than the above mentioned, please contact our Sales Department.

APPLICATION EXAMPLE



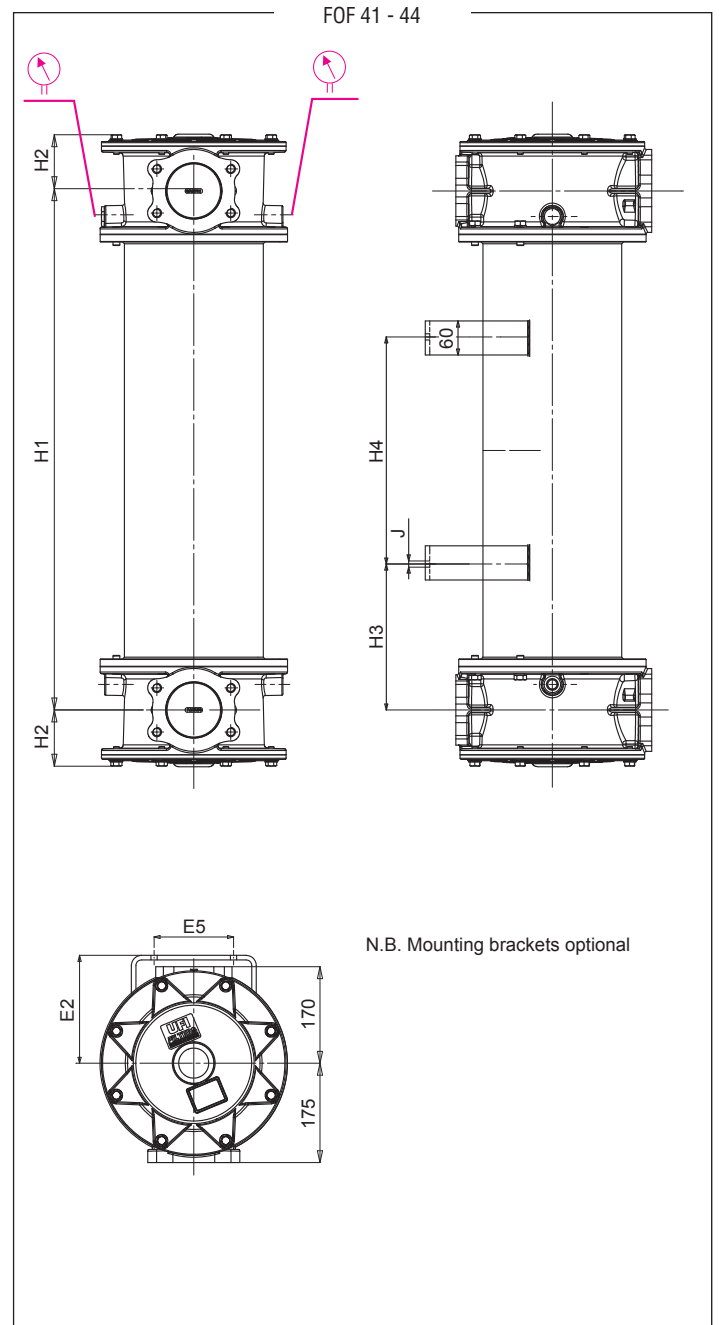
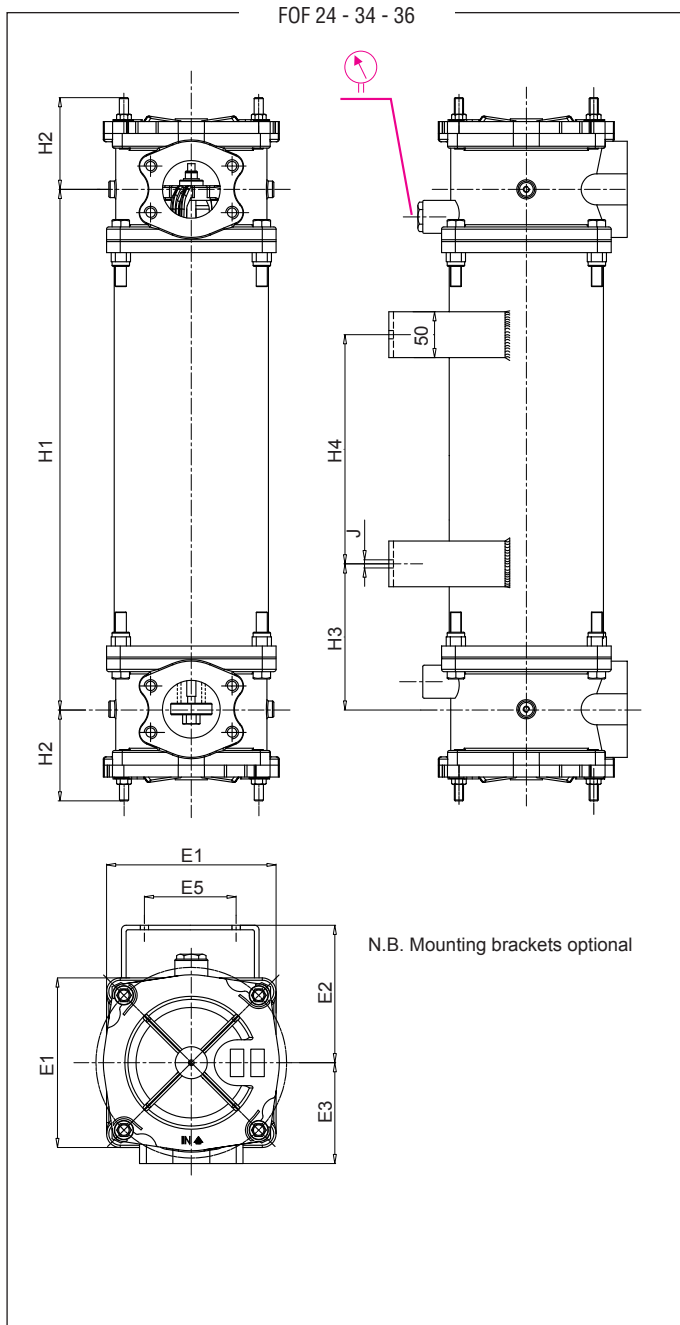

FILTER HOUSING

	PORT SIZE	E1	E2	E3	E5	H1	H2	H3	H4	J	R	Kg
FOF24	1" 1/2	150	132	90	70	513	93	130	250	9	580	18,0
FOF34	2" 1/2	185	150	110	100	568	82	135	250	9	620	19,6
FOF36	2" 1/2	185	150	110	100	770	82	165	250	9	820	
FOF41	3" - 4"	-	190	-	140	420	99	160	100	11	600	
FOF44	3" - 4"	-	190	-	140	1.180	99	340	500	11	1.360	

TYPE											
F = FILTER COMPLETE		F	F	F	F	F					
B = FILTER HOUSING		B	B	B	B	B	ELEMENT	E			
O F	FAMILY						FAMILY SIZE & LENGTH	R	F		
NOMINAL SIZE & LENGTH		24	34	36	41	44					
PORT TYPE											
B = BSP thread		B	-	-	-	-					
N = NPT thread		N	-	-	-	-					
S = SAE thread		S	-	-	-	-					
F = SAE flange 3000 psi		F	F	F	F	F					
PORT SIZE											
12 = 1"1/2		12	-	-	-	-					
20 = 2"1/2		-	20	20	-	-					
24 = 3"		-	-	-	24	24					
32 = 4"		-	-	-	32	32					
BYPASS VALVE											
W = without bypass		W	W	W	W	W					
F = 150 kPa (1,5 bar)		F	F	F	F	F					
SEALS							SEALS				
N = NBR Nitrile		N	N	N	N	N	N = NBR				
F = FKM Fluoroelastomer		F	F	F	F	F	F = FKM				
FILTER MEDIA							FILTER MEDIA				
FA = fiber 5 μm(e) β>1.000		FA	FA	FA	FA	FA	FA = fiber 5 μm(e)				
FB = fiber 7 μm(e) β>1.000		FB	FB	FB	FB	FB	FB = fiber 7 μm(e)				
FC = fiber 12 μm(e) β>1.000		FC	FC	FC	FC	FC	FC = fiber 12 μm(e)				
FD = fiber 21 μm(e) β>1.000		FD	FD	FD	FD	FD	FD = fiber 21 μm(e)				
CC = cellulose 10 μm β>2		CC	CC	CC	CC	CC	CC = cellulose 10 μm				
ME = wire mesh 60 μm β>2		ME	ME	ME	ME	ME	ME = wire mesh 60 μm				
WR = water removal (*)		WR	WR	WR	WR	WR	WR = water removal				
(*) Water removal media - see "hydro-dry" brochure											
CLOGGING INDICATOR											
03 = nr. 2 x 1/8" ports, plugged		03	03	03	03	03	When the filter is ordered with FKM seals, the first digit of the indicator code is a letter (please see page 186).				
5B = visual differential 130 kPa (1,3 bar)		5B	5B	5B	5B	5B					
6B = electrical differential 130 kPa (1,3 bar)		6B	6B	6B	6B	6B					
7B = indicator 6B with LED		7B	7B	7B	7B	7B					
T0 = elect. diff. 130 kPa (1,3 bar) with thermostat 30°C		T0	T0	T0	T0	T0					
N.B. Indicator series 70 only on request											
ACCESSORIES											
W = without accessory		W	W	W	W	W					
M = magnetic core		M	M	M	M	M					
ACCESSORIES											
W = without accessory		W	W	W	W	W					
B = mounting brackets		B	B	B	B	B					

FILTER ELEMENT

	A	B	C	kg	Area (cm ²)	
					Media F+	Media C+
ERF24	72	106	465	1,50	9.700	11.800
ERF34	92	126	480	2,20	12.800	15.400
ERF36	92	126	680	3,00	18.200	19.500
ERF41	157	203	330	3,90	17.900	22.100
ERF44	157	203	1.090	13,00	60.000	74.000

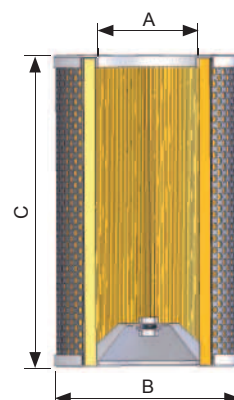

FLUID SPEED

when selecting the filter size, we suggest to consider also the max recommended fluid speed (in off-lines normally $1,5 < v < 4$ m/s)

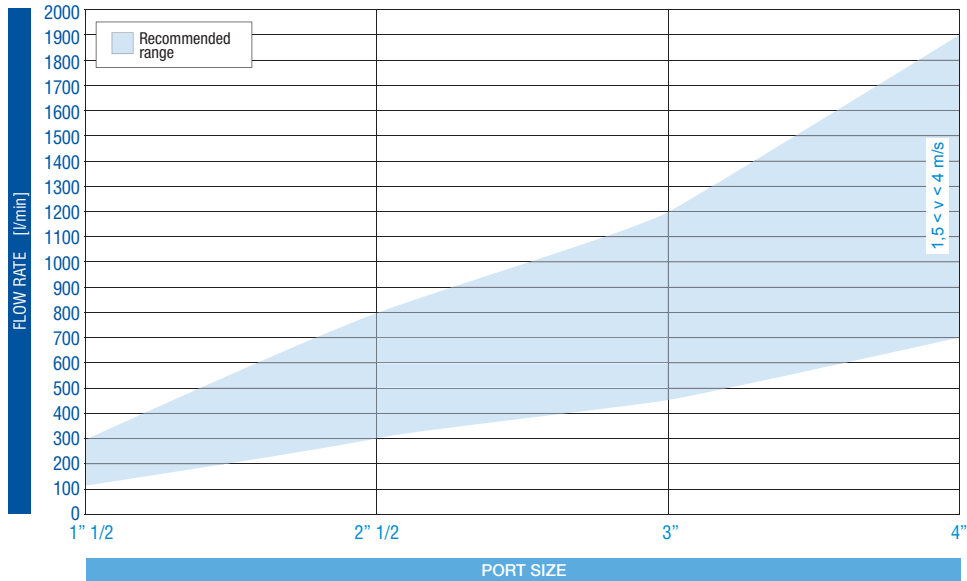

PRESSURE DROP CURVES (Δp)

The “Assembly Pressure Drop (Δp)” is obtained by adding the pressure drop values of the Filter Housing and of the Clean Filter Element corresponding to the considered Flow Rate and it must be lower than 50 kPa (0,5 bar).

FILTER HOUSING PRESSURE DROP (mainly depending on the port size)

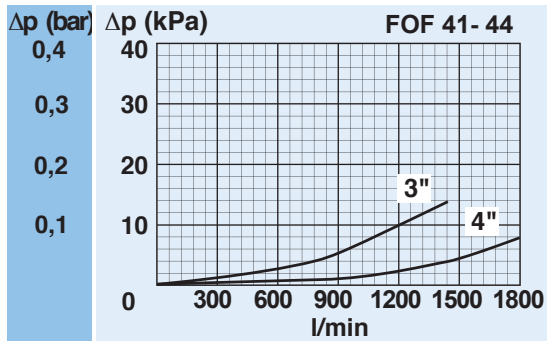
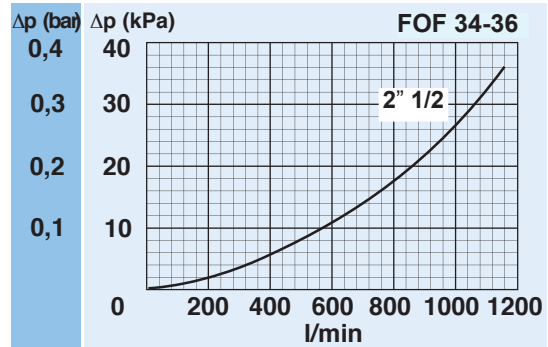
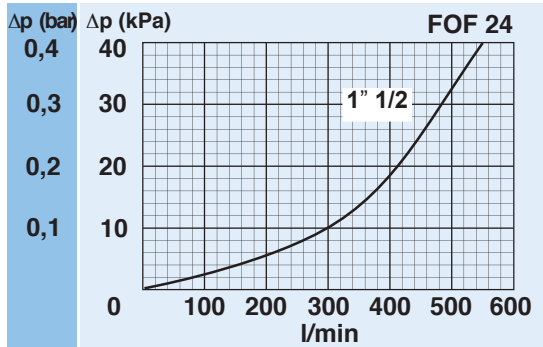

N.B. All the curves have been obtained with mineral oil having a kinematic viscosity 30 cSt and specific gravity 0,9 kg/dm³; for fluids with different features, please consider the factors described in the first part of this catalogue. All the curves are obtained from test done at the UFI HYDRAULIC DIVISION Laboratory, according to the specification ISO 3968. In case of discrepancy, please check the contamination level, viscosity and features of the fluid in use.

**CLEAN FILTER ELEMENT PRESSURE DROP
WITH F+, C+ AND ME MEDIA**

(depending both on the internal diameter of the element and on the filter media)

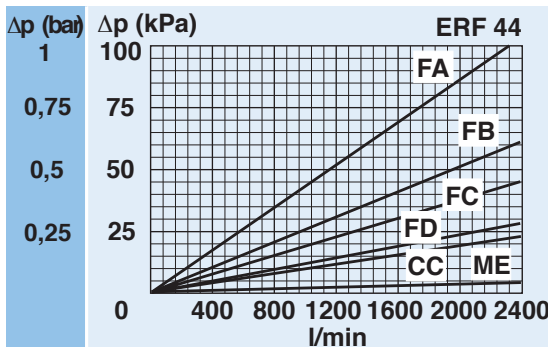
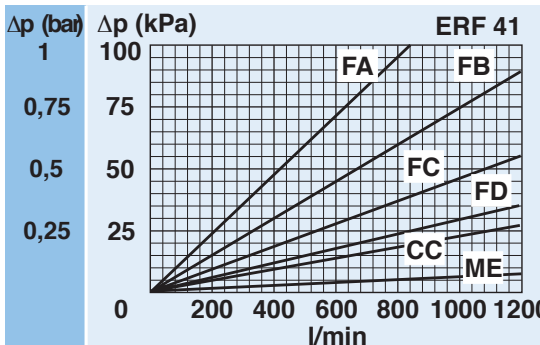
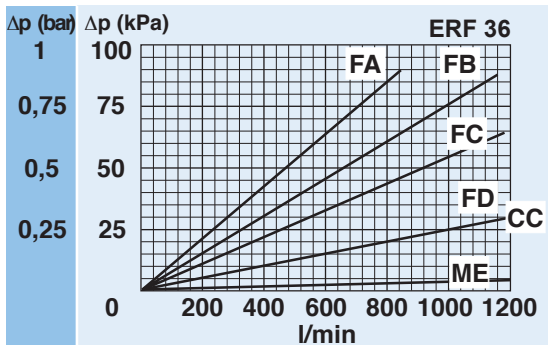
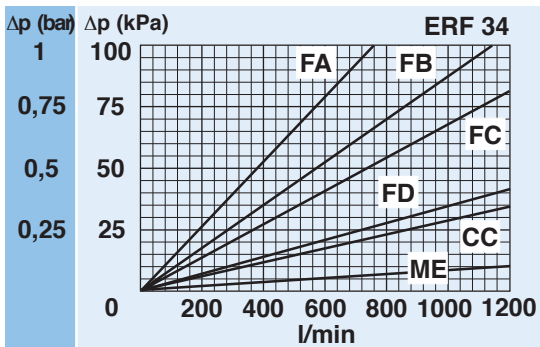
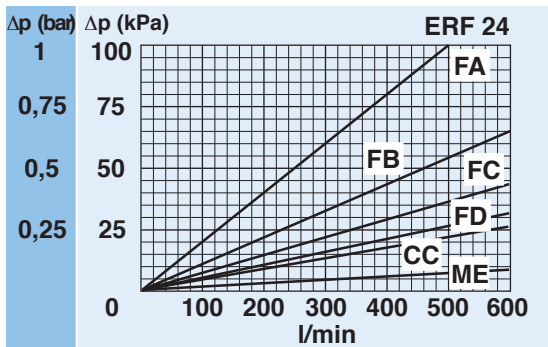

BYPASS VALVE PRESSURE DROP

When selecting the filter size, these curves must be taken into account if it is foreseen that any flow peak is to be absorbed by the bypass valve, it also must be of proper configuration to avoid pressure peaks. The valve pressure drop is directly proportional to fluid specific gravity.

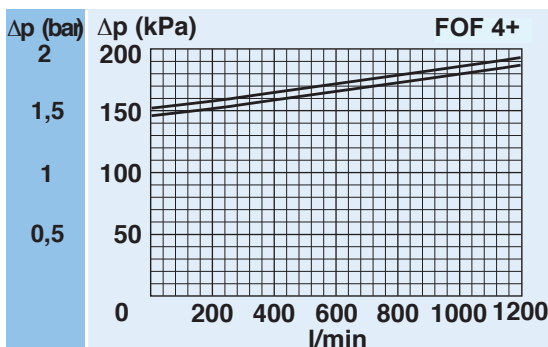
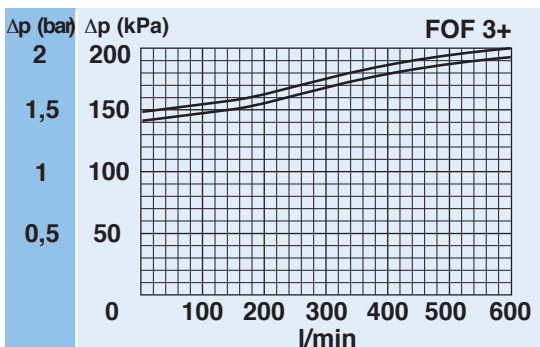
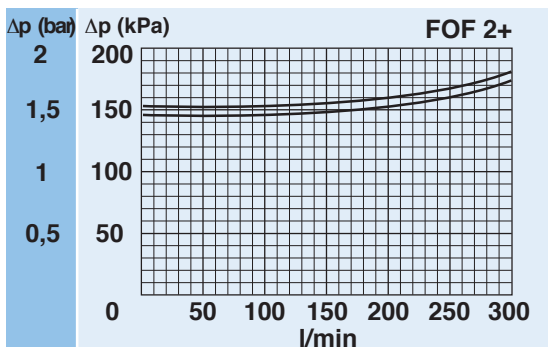

N.B. All the curves have been obtained with mineral oil having a kinematic viscosity 30 cSt and specific gravity 0,9 kg/dm³; for fluids with different features, please consider the factors described in the first part of this catalogue. All the curves are obtained from test done at the UFI HYDRAULIC DIVISION Laboratory, according to the specification ISO 3968. In case of discrepancy, please check the contamination level, viscosity and features of the fluid in use.

CLOGGING INDICATOR

A differential clogging indicator allows monitoring filter element and provides the exact time for replace the element.

BYPASS VALVE

The bypass function is obtained by the filter element moving axially, in such a way that the contaminant is retained in the filter element during bypass.

FILTER ELEMENT "LONG LIFE"

Filter elements are manufactured with a large surface area, in order to ensure a high dirt holding capacity. Inside to outside filtration ensures the contaminant is retained inside the element during replacement.

FLEXIBILITY OF INSTALLATION

Outlet port should be rotate by 90° interval respect to the inlet port, in order to obtain better mounting position and solve most of mounting problems.

CLOGGING INDICATOR

For further technical informations and other options see page 186.

 Differential

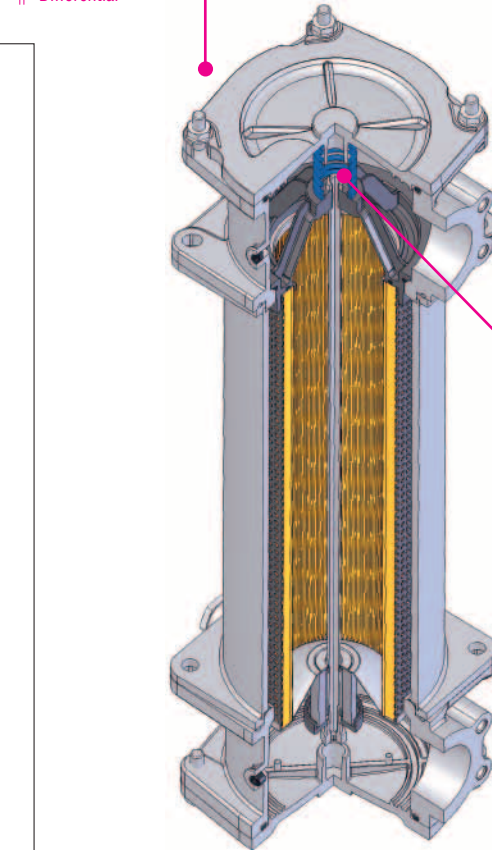
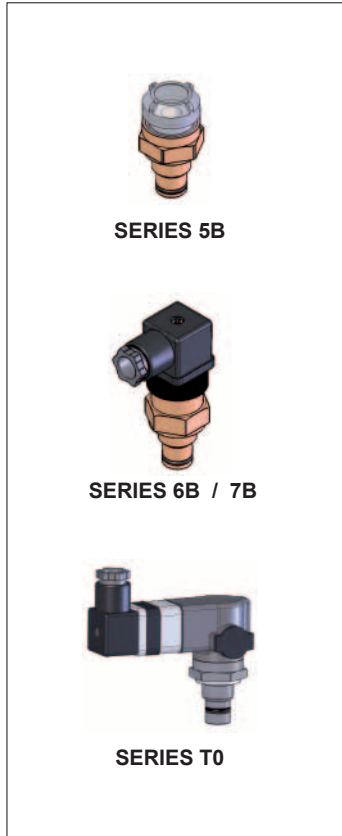

SPARE SEAL KIT

	NBR	FKM
FOF24	521.0101.2	521.0102.2
FOF34-36	521.0103.2	521.0104.2
FOF41-44	521.0105.2	521.0106.2

SPARE SPRING

FOF24	008.0269.1
FOF34-36	008.0275.1
FOF41-44	008.0283.1

SPARE PARTS ELEMENTS

(For filling up see table "Ordering and option chart")

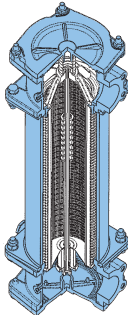
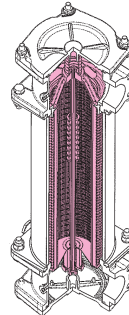
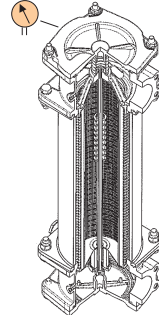
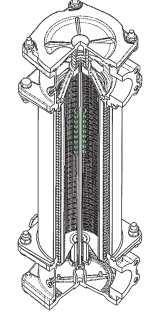
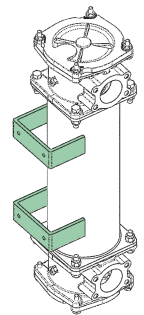
FILTER HOUSING	FILTER ELEMENT	CLOGGING INDICATOR	ACCESSORY	ACCESSORY
 <input type="checkbox"/>	 <input type="checkbox"/>	 <input type="checkbox"/>	 <input type="checkbox"/> MAGNETIC CORE	 <input type="checkbox"/> MOUNTING BRACKETS



Is this datasheet the latest release? Please check on our website.

