

# RC

## MATERIALS

Head:  
Aluminium alloy

Spin-on cartridge:  
Steel

Bypass valve:  
Polyamide

Seals:  
NBR Nitrile

Indicator housing:  
Brass

## PRESSURE (ISO 10771-1:2002)

Max working:  
700 kPa (7 bar)

Test:  
1 MPa (10 bar)

Bursting:  
2,1 MPa (21 bar)

Collapse, differential  
for the filter element (ISO 2941):  
300 kPa (3 bar)

## BYPASS VALVE

Setting:  
170 kPa (1,7 bar)  $\pm$  10%

## WORKING TEMPERATURE

From -25° to +110° C

## COMPATIBILITY (ISO 2943:1999)

Full with fluids: HH-HL-HM-HV-HTG  
(according to ISO 6743/4)  
For fluids different than the above mentioned,  
please contact our Sales Department.



## APPLICATION EXAMPLE



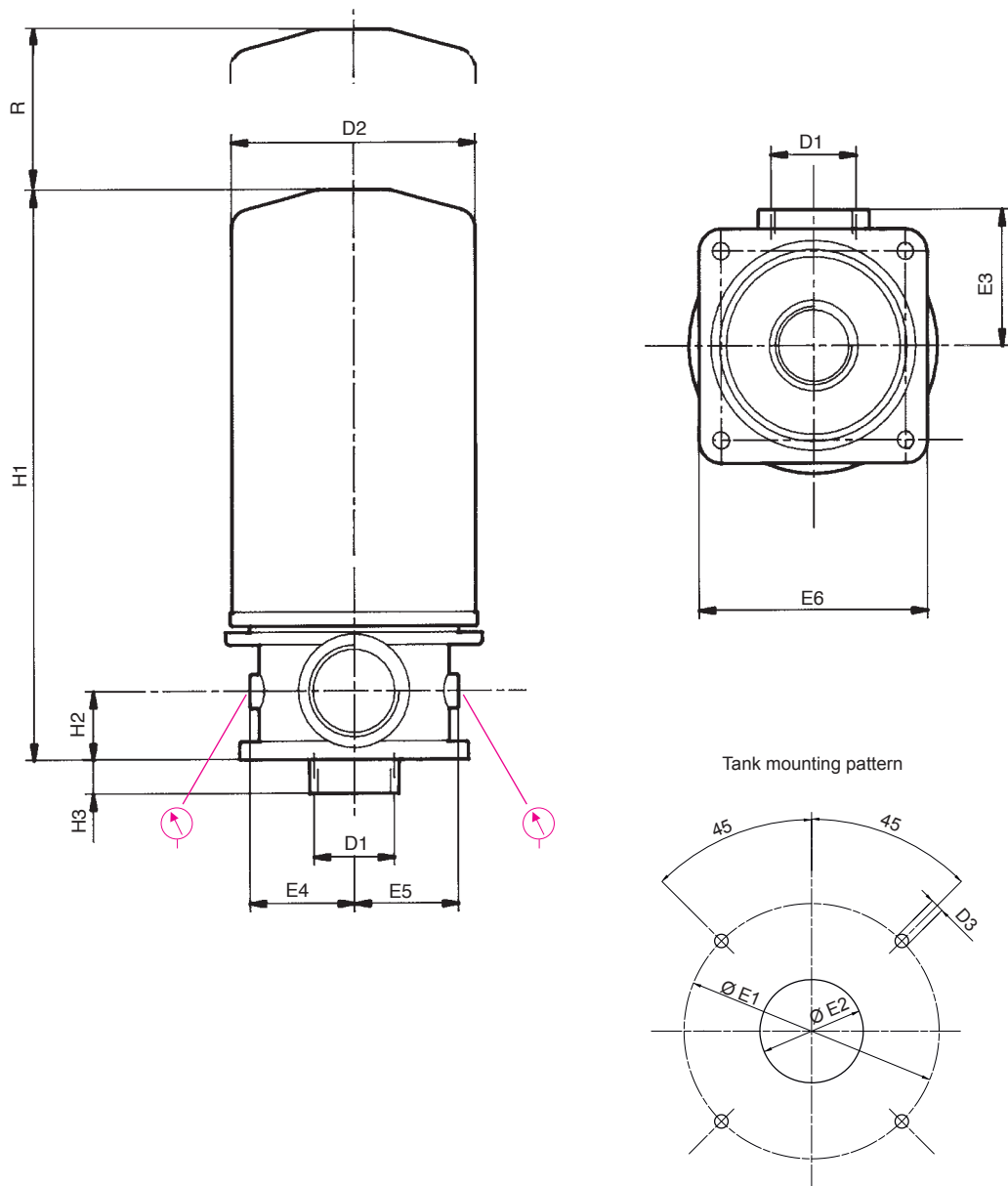

## FILTER HOUSING

	D1	D2	D3	H1	H2	H3	E1	E2	E3	E4	E5	E6	R	kg
FRC11	3/4"	95	7	196	25	18	99	40÷45	50	38	38	90	15	0,3+1,0
FRC12	3/4"	95	7	241	25	18	99	40÷45	50	38	38	90	15	0,3+1,3
FRC21	1" 1/2	130	9	252	36	18	141	65÷70	72	56	56	124	30	0,8+1,3
FRC22	1" 1/2	130	9	297	36	18	141	65÷70	72	56	56	124	30	0,8+1,4

		<b>TYPE</b>					
		F = FILTER COMPLETE	F	F	F	F	
		B = FILTER HOUSING	B	B	B	B	<b>ELEMENT</b> E
R	C	<b>FAMILY SIZE &amp; LENGTH</b>				<b>FAMILY SIZE &amp; LENGTH</b> R C	
		11	12	21	22		
		<b>PORT TYPE</b>					
		B = BSP thread	B	B	B	B	
		<b>PORT SIZE</b>					
		06 = 3/4"	06	06	-	-	
		12 = 1" 1/2	-	-	12	12	
		<b>BYPASS VALVE</b>					
		B = 170 kPa (1,7 bar)	B	B	B	B	
		<b>SEALS</b>				<b>SEALS</b> N	
		N = NBR Nitrile	N	N	N	N	N = NBR
		<b>FILTER MEDIA</b>				<b>FILTER MEDIA</b>	
		FB = fiber 7 $\mu\text{m}_{(e)}$ $\beta > 1.000$	FB	FB	FB	FB	FB = fiber 7 $\mu\text{m}_{(e)}$
		FC = fiber 12 $\mu\text{m}_{(e)}$ $\beta > 1.000$	FC	FC	FC	FC	FC = fiber 12 $\mu\text{m}_{(e)}$
		FD = fiber 21 $\mu\text{m}_{(e)}$ $\beta > 1.000$	FD	FD	FD	FD	FD = fiber 21 $\mu\text{m}_{(e)}$
		CC = cellulose 10 $\mu\text{m}$ $\beta > 2$	CC	CC	CC	CC	CC = cellulose 10 $\mu\text{m}$
		CD = cellulose 25 $\mu\text{m}$ $\beta > 2$	CD	CD	CD	CD	CD = cellulose 25 $\mu\text{m}$
		<b>CLOGGING INDICATOR</b>					
		05 = nr. 2 x 1/8" ports, plugged	05	05	05	05	
		30 = pressure gauge, rear connection	30	30	30	30	
		P1 = SPDT, pressure switch	P1	P1	P1	P1	
X	X	<b>ACCESSORIES</b>					
		X X = no accessory available	XX	XX	XX	XX	

**FILTER ELEMENT**

	A	B	C	kg	Area (cm <sup>2</sup> )	
					Media F+	Media C+
ERC11	96,5	3/4" BSP	146	1,00	2.140	3.305
ERC12	96,5	3/4" BSP	191	1,20	3.630	4.745
ERC21	129	1" 1/4 BSP	181	1,40	4.450	5.560
ERC22	129	1" 1/4 BSP	226	1,50	5.890	7.360

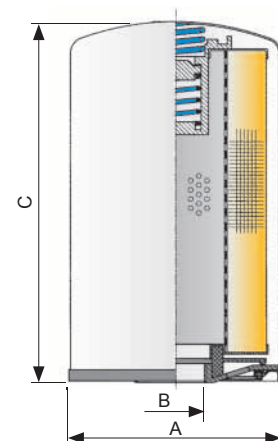

**FLUID SPEED**

when selecting the filter size, we suggest to consider also the max recommended fluid speed (in return lines normally  $1,5 < v < 4$  m/s)

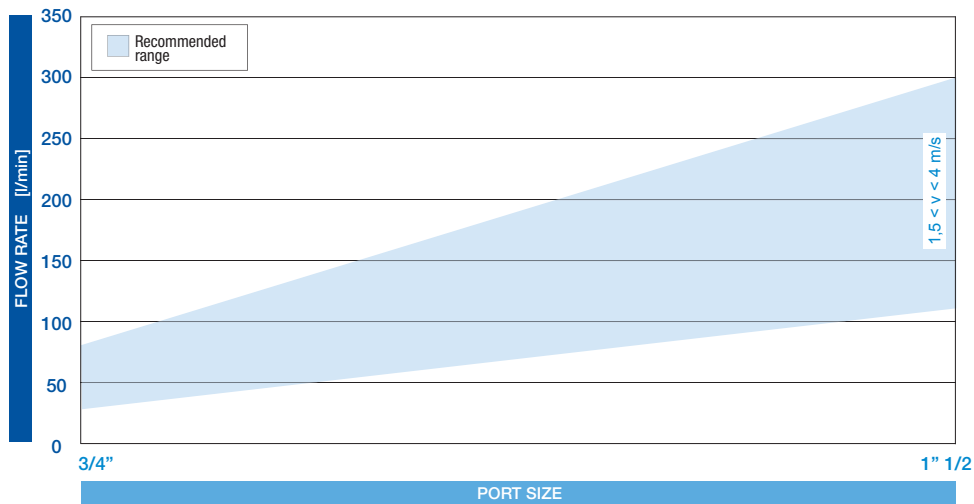

**PRESSURE DROP CURVES ( $\Delta p$ )**

The “Assembly Pressure Drop ( $\Delta p$ )” is obtained by adding the pressure drop values of the Filter Housing and of the Clean Filter Element corresponding to the considered Flow Rate and it must be lower than 50 kPa (0,5 bar).

**FILTER HOUSING PRESSURE DROP**  
(mainly depending on the port size)

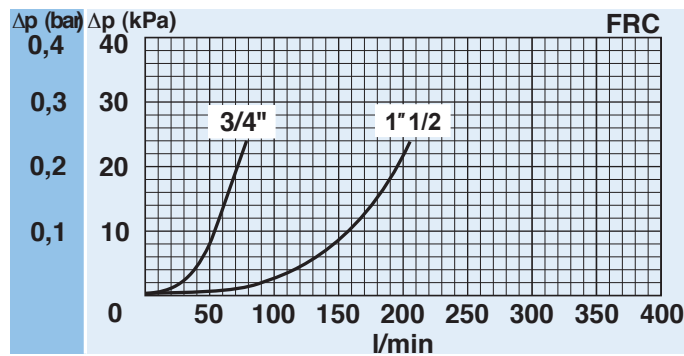

N.B. All the curves have been obtained with mineral oil having a kinematic viscosity 30 cSt and specific gravity 0,9 kg/dm<sup>3</sup>; for fluids with different features, please consider the factors described in the first part of this catalogue. All the curves are obtained from test done at the UFI HYDRAULIC DIVISION Laboratory, according to the specification ISO 3968:2005. In case of discrepancy, please check the contamination level, viscosity and features of the fluid in use.

PRESSURE DROP CURVES ( $\Delta p$ )

The "Assembly Pressure Drop ( $\Delta p$ )" is obtained by adding the pressure drop values of the Filter Housing and of the Clean Filter Element corresponding to the considered Flow Rate and it must be lower than 50 kPa (0,5 bar).

**CLEAN FILTER ELEMENT PRESSURE DROP  
WITH F+ AND C+ MEDIA**

(depending both on the internal diameter of the element and on the filter media)

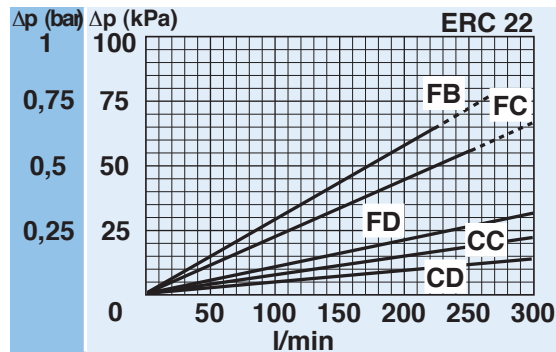
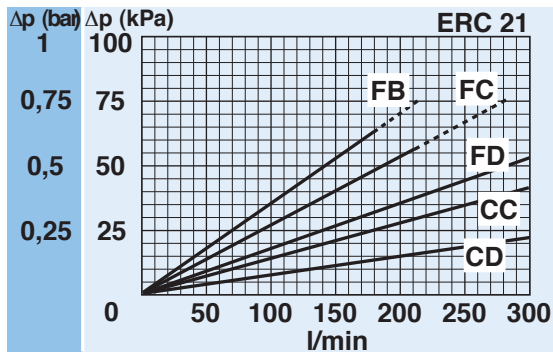
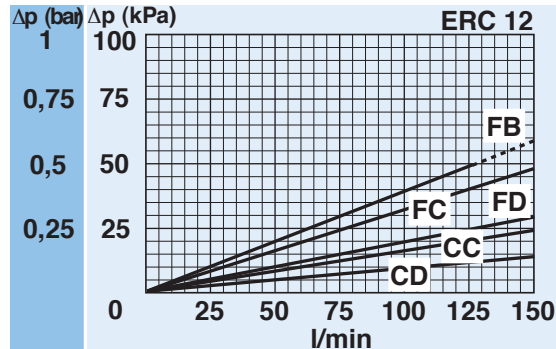
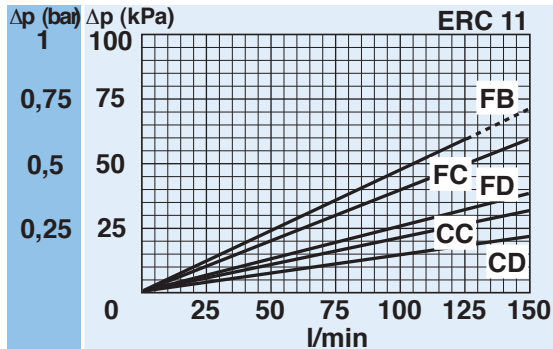

## BYPASS VALVE PRESSURE DROP

When selecting the filter size, these curves must be taken into account if it is foreseen that any flow peak is to be absorbed by the bypass valve, it also must be of proper configuration to avoid pressure peaks. The valve pressure drop is directly proportional to fluid specific gravity.

