

# 液压泵保护 吸油过滤器

## SA & SB

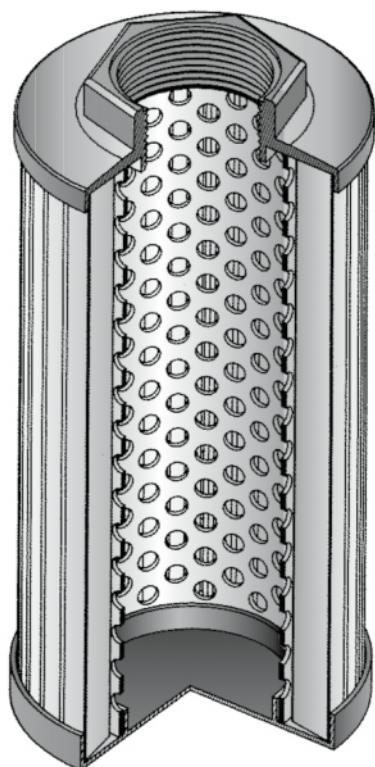

### 材质

连接部分:  
聚酰胺

底盖:  
聚酰胺

旁通阀:  
聚酰胺

磁铁:  
磁性材料

### 压力参数

滤芯爆破压差:  
100 kPa (1 bar)

### 旁通阀

开启压力设置:  
30 kPa (0.3 bar) +/-10%

### 工作温度范围

-25°C 到 +110°C

### 适用介质

HH-HL-HM-HR-HV-HG (参照国际标准:  
ISO 6743/4) 特殊介质, 请与销售部联系。

## 安装尺寸

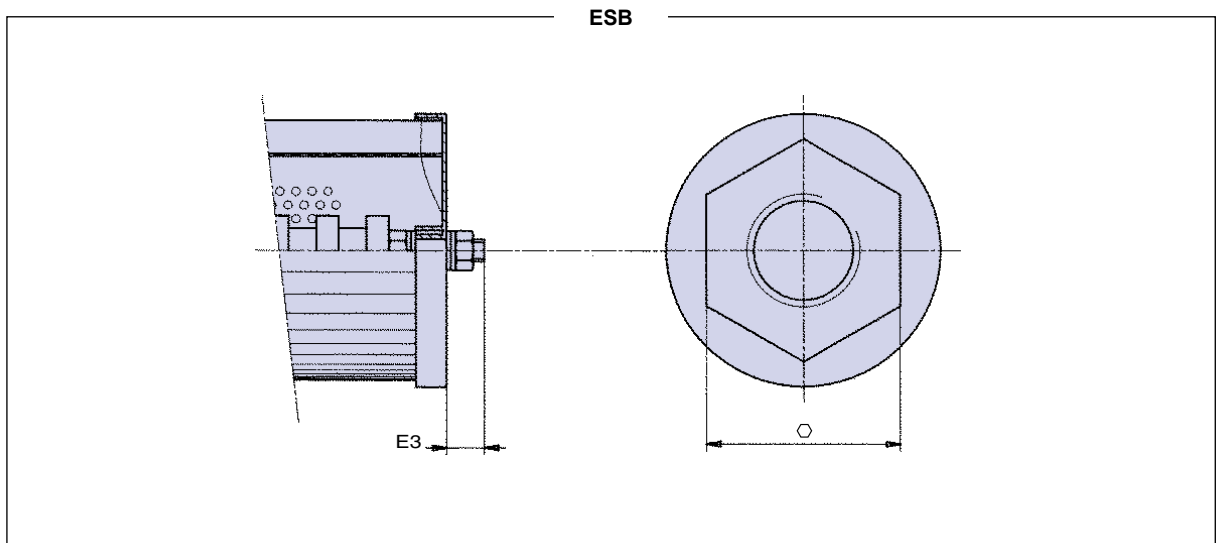
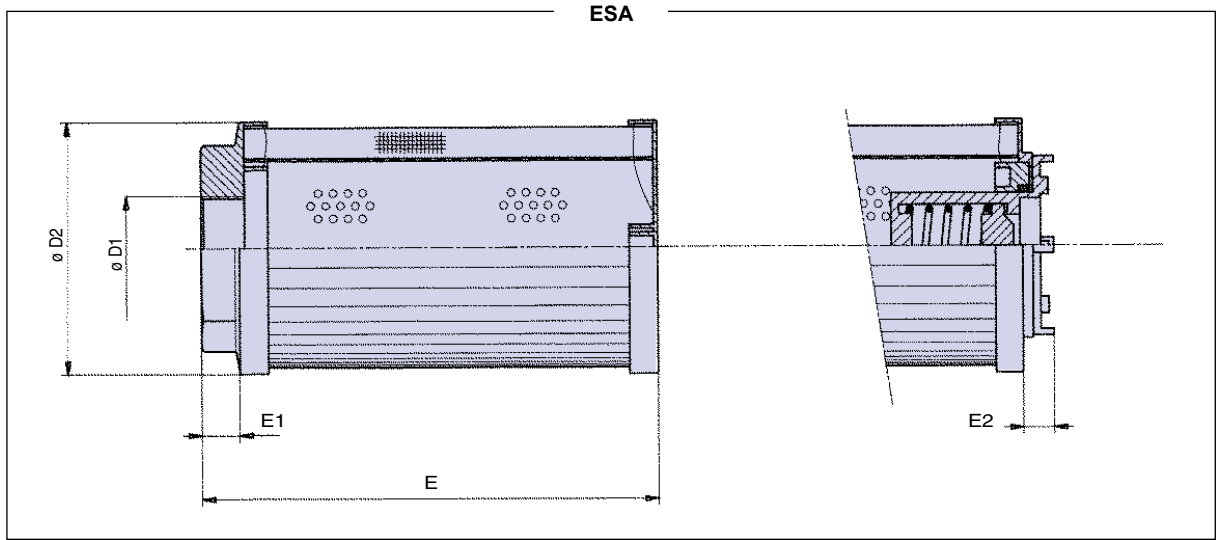

## 外形和重量

### 滤芯

	D1	D2	E	E1	E2	E3	○	kg - SA	kg - SB
ESA & ESB11	3/8" - 1/2"	52	73	12	13	9	30	0.05	0.10
ESA & ESB21	1/2" - 3/4"	70	92	13	11	12	42	0.25	0.30
ESA & ESB22	3/4" - 1"	70	137	13	11	13	42	0.25	0.30
ESA & ESB30	1 1/4" - 1 1/2"	99	135	15	12	12	70	0.30	0.35
ESA & ESB31	1 1/4" - 1 1/2"	99	178	15	12	12	70	0.40	0.45
ESA & ESB32	1 1/4" - 1 1/2" - 2"	99	218	15	12	14	70	0.50	0.60
ESA & ESB40	1 1/2" - 2"	130	160	15	15	14	70	0.50	0.60
ESA & ESB41	1 1/2" - 2"	130	201	15	15	14	70	0.70	0.80
ESA & ESB42	2" - 2 1/2" - 3"	130	253	15	25	14	101	1.00	1.20
ESA & ESB43	3"	130	330	15	25	14	101	1.30	1.50
ESA & ESB51	3 1/2"	180	390	35	-	4	140	2.80	3.00
ESA & ESB52	4"	180	440	35	-	4	140	3.00	3.20

## 压力损失曲线 ( $\Delta p$ )

压降( $\Delta p$ )必须低于3 kPa (0.03 bar).

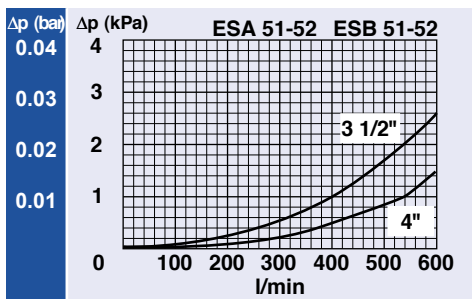
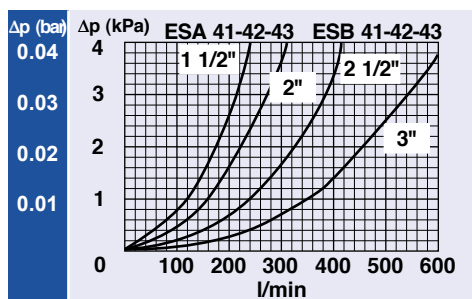
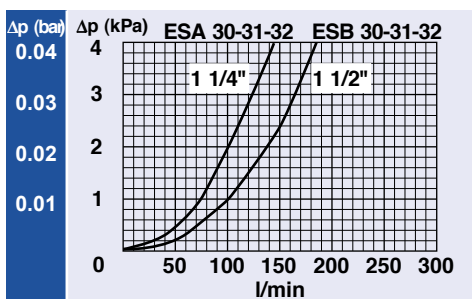
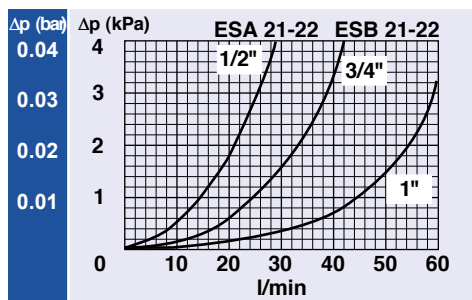
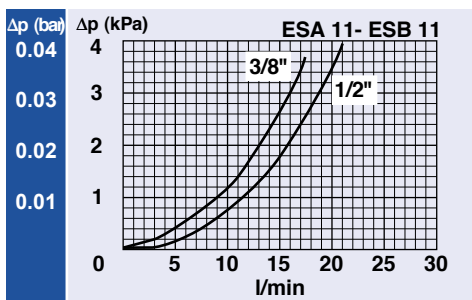

样本中提供的压降曲线是按照ISO3968:2005标准规定的试验要求，使用动力粘度为30cSt，密度为0.9的矿物油的条件下测量得到的。实际使用过程中，如果使用不同特性的油液，请对由上述曲线中查得的压降进行修正。修正方法请查看本样本首页中过滤知识介绍一文。

订货和选型

<b>S</b>	<b>A</b>	<b>E</b> 滤芯												
		系列, 尺寸和长度	11	21	22	30	31	32	40	41	42	43	51	52
		油口类型												
		B = BSP 螺纹	B	B	B	B	B	B	B	B	B	B	B	B
		N = NPT 螺纹	N	N	N	N	N	N	N	N	N	N	-	-
		油口尺寸												
		03 = 3/8"	03	-	-	-	-	-	-	-	-	-	-	-
		04 = 1/2"	04	04	-	-	-	-	-	-	-	-	-	-
		06 = 3/4"	-	06	06	-	-	-	-	-	-	-	-	-
		08 = 1"	-	-	08	-	-	-	-	-	-	-	-	-
		10 = 1 1/4"	-	-	-	10	10	10	-	-	-	-	-	-
		12 = 1 1/2"	-	-	-	12	12	12	12	12	-	-	-	-
		16 = 2"	-	-	-	-	-	16	16	16	16	-	-	-
		20 = 2 1/2"	-	-	-	-	-	-	-	-	20	-	-	-
		24 = 3"	-	-	-	-	-	-	-	-	24	24	-	-
		28 = 3 1/2"	-	-	-	-	-	-	-	-	-	-	28	-
		32 = 4"	-	-	-	-	-	-	-	-	-	-	-	32
		旁通阀												
		W = 不带旁通阀	W	W	W	W	W	W	W	W	W	W	W	W
		A = 30 kPa (0.3 bar)	A	A	A	A	A	A	A	A	A	A	-	-
		滤材												
		ME = 金属丝网60µm	ME	ME	ME	ME	ME	ME	ME	ME	ME	ME	ME	ME
		MF = 金属丝网90µm	MF	MF	MF	MF	MF	MF	MF	MF	MF	MF	MF	MF
		MG = 金属丝网250µm	MG	MG	MG	MG	MG	MG	MG	MG	MG	MG	MG	MG

<b>S</b>	<b>B</b>	<b>E</b> 滤芯												
		系列, 尺寸和长度	11	21	22	30	31	32	40	41	42	43	51	52
		油口类型												
		B = BSP 螺纹	B	B	B	B	B	B	B	B	B	B	B	B
		N = NPT 螺纹	N	N	N	N	N	N	N	N	N	N	-	-
		油口尺寸												
		03 = 3/8"	03	-	-	-	-	-	-	-	-	-	-	-
		04 = 1/2"	04	04	-	-	-	-	-	-	-	-	-	-
		06 = 3/4"	-	06	06	-	-	-	-	-	-	-	-	-
		08 = 1"	-	-	08	-	-	-	-	-	-	-	-	-
		10 = 1 1/4"	-	-	-	10	10	10	-	-	-	-	-	-
		12 = 1 1/2"	-	-	-	12	12	12	12	12	-	-	-	-
		16 = 2"	-	-	-	-	-	16	16	16	16	-	-	-
		20 = 2 1/2"	-	-	-	-	-	-	-	-	20	-	-	-
		24 = 3"	-	-	-	-	-	-	-	-	24	24	-	-
		28 = 3 1/2"	-	-	-	-	-	-	-	-	-	-	28	-
		32 = 4"	-	-	-	-	-	-	-	-	-	-	-	32
		<b>X</b> 旁通阀												
		X = 不带旁通阀	X	X	X	X	X	X	X	X	X	X	X	X
		滤材												
		ME = 金属丝网60µm	ME	ME	ME	ME	ME	ME	ME	ME	ME	ME	ME	ME
		MF = 金属丝网90µm	MF	MF	MF	MF	MF	MF	MF	MF	MF	MF	MF	MF
		MG = 金属丝网250µm	MG	MG	MG	MG	MG	MG	MG	MG	MG	MG	MG	MG

滤芯

E|S| | | | | | | |